



Ron Davis Racing Products

Custom Aluminum Radiators

RON DAVIS RACING PRODUCTS has been manufacturing racing and special application radiators for over 28 years. Utilizing the finest materials and skilled craftsman, we produce the most efficient, reasonably priced high performance radiator on the market today! Whether you race on pavement, dirt, oval, road course, drag, or off-road, RON DAVIS RACING PRODUCTS will give you the competitive edge!

DRAG RACING RADIATORS

From staging lanes, return road trips, and quick cool downs between rounds is where Ron Davis Racing Products Drag racing radiators are engineered for maximum performance. Made with the latest technology and skilled craftsman Ron Davis Racing Product's radiators are vastly superior.



JIM HUGHES
2002 NHRA SUPER COMP WORLD CHAMPION
MULTI NHRA & IHRA NATIONAL EVENT WINNER

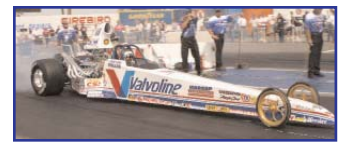
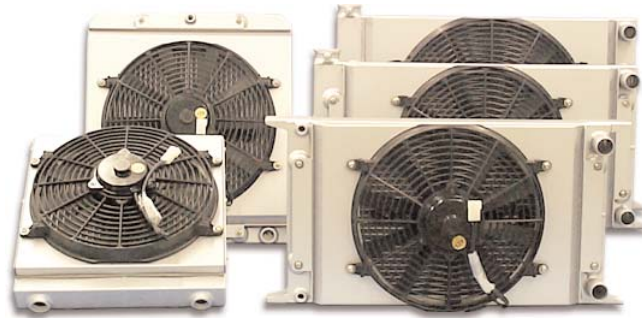

ROD FULLER
2003 NHRA SUPER COMP WORLD CHAMPION
13 NATIONAL EVENT WINS
28 DIVISIONAL WINS
82 TOTAL WINS

IN STOCK CALL TODAY!



PAT MUSI
2003 NSCA PRO STREET CHAMPION
PRO-EDELBROCK PRO STREET CHAMPION

Part #	Width	Height	Thick
1A-1100-1	25"	12.75"	2"
1A-1120-1	22"	12.75"	2"
1A-1130-1	25"	16"	2"
1A-1140-1	17.37"	20"	2"
1A-1150-1	14"	16"	2"



P/N# 1A-1161-1

SPRINT CAR RADIATORS



JJ YELEY
2003 USAC TRIPLE CROWN CHAMPION

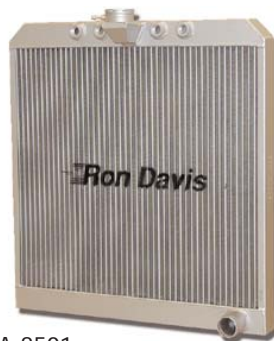

#1A-8501

Part #	Width	Height	Thick
8501	20"	22"	2"
8502	12.5"	21"	2"
8503	20"	20"	2"
8504	19"	20"	2"

ACCESSORIES



BILLET ALUMINUM FITTINGS



COOLANT RECOVERY TANKS



FAN RELAY HARNESS KITS

UNIVERSAL STOCK CAR & OFF-ROAD RADIATORS



Robby Gordon



Collins Motorsports

Features

- No Epoxy
- 2 rows of 1" wide tubes
- Furnace Brazed Cores
- 100% Tig Welded
- Pressure Tested @ 32 psi.
- 6061-T6 Outlets & Mounting Bosses
- Stainless Steel Hardware
- Race Proven Performance
- Lightweight Aluminum Construction

Available options:

- Ford style outlet location
- Transmission oil cooler
- Engine oil cooler
- Double pass configuration
- Pipe thread fittings
- AN type fittings
- No filler neck
- Electric fan & shroud assembly
- 2 row 1.250" tube core



#1A-22193T-1

22" wide X 19" tall X 3" thick Chevy style Stock Car Radiator with an automatic transmission cooler, 16" Spal fan, and our aluminum shroud assembly

Regular Pass



#1A-28193

28" wide X 19" tall X 3" thick Chevy style Stock Car Radiator

Double Pass



#1A-31193D

31" wide X 19" tall X 3" thick Chevy Double Pass Stock Car Radiator

19" Tall

Part #	Width	Height	Thick
1A-22193	22"	19"	3"
1A-24193	24"	19"	3"
1A-26193	26"	19"	3"
1A-28193	28"	19"	3"
1A-31193	31"	19"	3"

16" Tall

Part #	Width	Height	Thick
1A-22163	22"	16"	3"
1A-24163	24"	16"	3"
1A-26163	26"	16"	3"
1A-28163	28"	16"	3"
1A-31163	31"	16"	3"

Rick Johnson



Campbell Enterprises



#1A-31163D-2

31" wide X 16" tall X 3" thick Chevy double pass Stock Car radiator with dual Spal fans and aluminum shroud assembly

ALL POPULAR MAKES & MODELS AVAILABLE!



P/N# 11-254005-3
JAGUAR E TYPE 4.2 SERIES 1
W/ ELECTRIC FAN & BRACKET



P/N# 1-16H1
HUMMER H1 HEAVY DUTY RADIATOR



"This radiator is a work of art!" - Jesse James
West Coast Choppers



P/N# 11-16CL6877
'68-'77 CHEVELLE / EL CAMINO W/
DUAL ELECTRIC FAN & SHROUD
ASSEMBLY



P/N# 1-16H2
HUMMER H2 HEAVY DUTY RADIATOR
WITH INTEGRATED OIL COOLERS



P/N# 11-16CA6900
'67-'69 CAMARO/FIREBIRD W/ DUAL 13" SPAL
FAN & ALUMINUM SHROUD ASSEMBLY



65-66 GALAXIE 390/427 RADIATOR



P/N# 1-50BR50
'66-'77 BRONCO RADIATOR WITH 5.0 ENGINE



In the spring I bought/installed a new Ron Davis Radiator for my 69 Camaro with their shroud and dual fans. On Saturday, we drove from Valencia, CA to Huntington Beach, CA (about 80-90 miles). When we left, the outside temp was about 101*, and traffic was stop and go the whole way. Well, I ran the a/c the whole time, and the coolant temp never got above 180*!! On Sunday we went to the "Chevy Madness" show, and then drove home in the late afternoon. Again, we ran the a/c the whole time and the motor never ran hot.

I previously ran one of their competitors aluminum radiators with a single 15" Flex-a-Lite electric puller fan. On hot days I would have to turn off the a/c and the motor would still get up to 220*!!

Anyway, thanks again to Tim and everyone at RDR for making a great product.

Frank

CORVETTE REPLACEMENT TYPE RADIATORS



P/N# 1-16CV5559
'55-'59 CORVETTE



P/N# 1-16CV6973
'69-'73 CORVETTE W/ AUTOMATIC TRANSMISSION

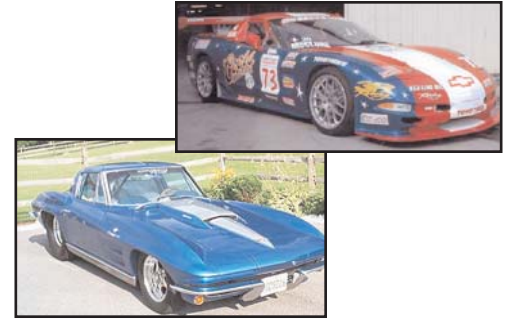

P/N# 1-16CV6162
'61-'62 CORVETTE



P/N# 1-16CV7376
'73-'76 CORVETTE



P/N# 1-16CV8996
'90-'96 CORVETTE
(ALSO FITS '89 HI ALTITUDE OPTION)



P/N# 1-16CV6372
'63-'72 CORVETTE

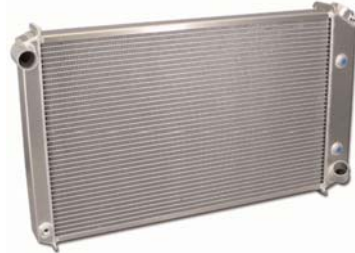

P/N# 1-16CV7779
'77-'79 CORVETTE



P/N# 1-16CV9096
'90-'96 CORVETTE W/ AUTOMATIC TRANSMISSION
(ALSO FITS '89 HI ALTITUDE OPTION)



P/N# 1-16CV6530
1965 BIG BLOCK CORVETTE

Features

- No Epoxy
- Furnace Brazed Cores
- 100% Tig Welded
- Pressure Tested @ 32 psi.
- 6061-T6 Outlets & Mounting Bosses
- Stainless Steel Hardware
- Race Proven Performance
- Lightweight Aluminum Construction



P/N# 1-16CV9700
'97-'04 C5 CORVETTE W/ AUTOMATIC TRANSMISSION



P/N# 1-16CV6972
'69-'72 CORVETTE

Gentleman,

It was great being able to help you guys with the fit of the RDR Radiator in my '93 Corvette so others may benefit from our experience. Very few people impress me with their knowledge of cars, and you and your team were great. This is probably the best money I've spent on my car. The car now runs at least 20 degrees cooler under any conditions. I wish I'd done it sooner. 199k miles and still COOL!!

Dale Snyder



P/N# 1-16CV0500
2005 C6 CORVETTE WITH INTEGRATED ENGINE OIL COOLER

2003 Copyright Ron Davis Racing Products

1-800-842-5166 / 623-877-5000 / Fax: 623-877-5001 / www.rondavisradiators.com

CUSTOM BUILT RADIATORS

Custom built aluminum radiators require a drawing or a sample.
Fax drawings to 623-877-5001

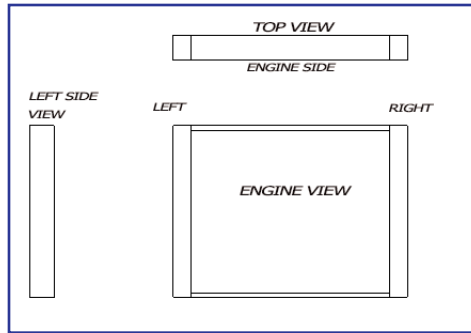

CHAMPIONSHIP WINNING RADIATORS



Dorsey Patrick Photos



2000 Winston Cup Champion
Bobby Labonte



2002 Winston Cup Champion
Tony Stewart



Michael Waltrip

Kent Steele Photo



Frank Kimmel
6 Time ARCA Champion



Tri-Point Racing



Robby Gordon



We offer specialized application radiators for Short tracks, Intermediate tracks, and Super Speedways. For more information please call 1-800-842-5166

SALES POLICY AND SHIPPING INFORMATION

Terms Of Sale: Shipments are C.O.D. money order / cashier's check or prepaid by Visa or MasterCard. All items are F.O.B. Glendale Plant Dock. UPS is our preferred carrier. All next day, 2 day and 3-day Select shipments are prepaid. Pricing: All prices are subject to change without prior notice. Orders not filled at the time of an increase will not be affected. **Limited Warranty** - For a period of 90 days, Ron Davis Racing Products warrants that the products sold here under shall be free of defects in workmanship or materials. THIS WARRANTY IS EXCLUSIVE AND IN LIEU OF ANY WARRANTY OF MERCHANTABILITY, FITNESS FOR A PARTICULAR PURPOSE, OR OTHER WARRANTY OF QUALITY, WHETHER EXPRESS OR IMPLIED. Ron Davis Racing Products does not warrant or guarantee installation or adjustment of the part. This warranty does not cover damage due to misuse, abuse, negligence, improper installation, acts of God or other causes beyond the control of Ron Davis Racing Products. Any alteration or Misuse of the product after manufacture voids this warranty in its entirety. In no event shall Ron Davis Racing Products be responsible for any indirect, incidental or consequential damages. In the event of a defect in workmanship or materials, purchaser's or other user's sole and exclusive remedy is for repair or replacement of the part without charge.

Features

- No Epoxy
- Furnace Brazed Cores
- 100% Tig Welded
- Pressure Tested @ 32 psi.
- 6061-T6 Outlets & Mounting Bosses
- Stainless Steel Hardware
- Race Proven Performance
- Lightweight Aluminum Construction



7334 North 108th Avenue Glendale, AZ. 85307

1-800-842-5166 / 623-877-5000 / Fax: 623-877-5001 / www.rondavisradiators.com